

Protema PRO100ESE drum tipper

Short info on drums:

Drums are frequently used in the pharmaceutical industry to carry tablets, powders and sometimes fluids in the manufacturing process.

- The fixed version drum turner is perfect for one-size drum projects. It consists of a bracket that holds the drum in place when it is manually emptied of its contents.
- For projects with drums of varying dimension the EasySqueeze unit is more suitable.
- It is advisable to suggest an electric turner instead of a manual turning solution when the load reaches 60 kg or more.
- When drums are emptied at a height, we recommend the electric tilting function.

Two applications in one drum lifter

Project nr: DL03153

Project supervisor:

Mark Roberts, TAWI UK, England

Project engineer:

David Lorensen, TAWI AB Sweden

Max capacity, this version:

PRO100ESE max 30 kg with center of load @ 504 mm from mast

- 1) Rotating 180 degrees vertical to empty drums into hopper.
- 2) Turning in the opposite direction, 130 degrees to dispense into weighing scales.

PRO100ESE has been equipped with the following additional features to suit this pharmaceutical application:

- V-shaped legs (to reach around and pick-up drum from pallet corner.
- Fixed arms with shells for drums with $\text{Ø}360$ mm.
- Turning configuration; 180° in one direction and 130° in the other direction.

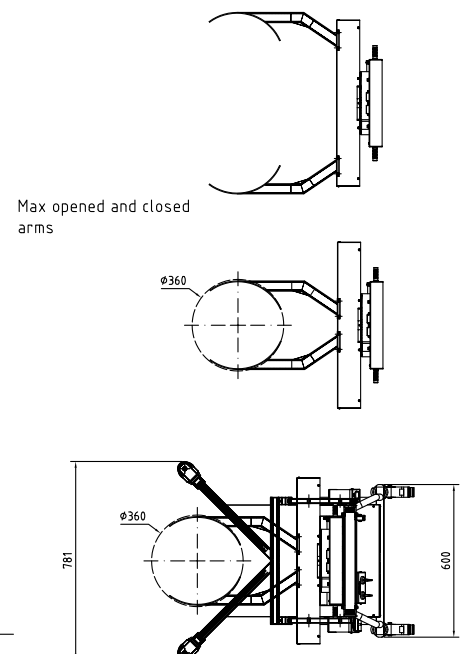
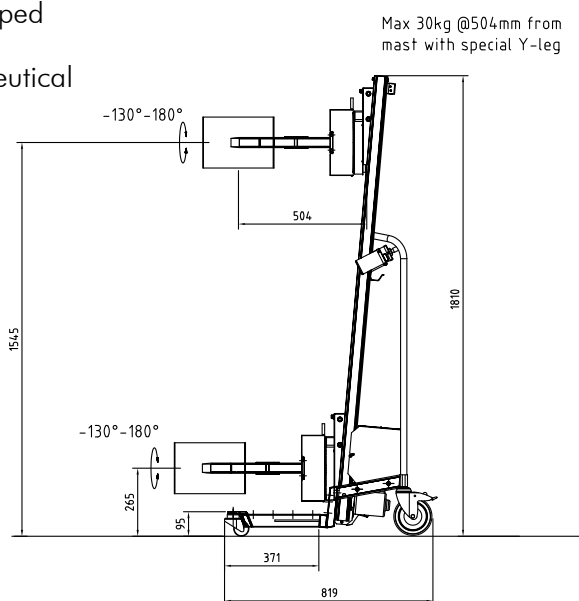

TAWI
Protema

Box 10205 434 23 KUNGSBACKA Sweden
Tel +46 300 185 00
info@tawi.se
www.TAWI.com